

VALIDATION OF A SIMPLIFIED BUILDING MODEL USED FOR CITY DISTRICT SIMULATION

Jens Teichmann, Moritz Lauster, Marcus Fuchs, Rita Streblow, Dirk Müller
RWTH Aachen University, E.ON Energy Research Center, Institute for Energy Efficient
Buildings and Indoor Climate, 52074 Aachen, Deutschland

Corresponding author email: jteichmann@eonerc.rwth-aachen.de

ABSTRACT

Dynamic city districts modelling considers large scale energy systems. Thus, there is a need for building models with short computation times, sufficient accuracy and low effort for parameterization. To this aim, we developed a simplified building model. This paper compares the simulation results of this model for five different non-residential buildings with measurement data for about one year and contrasts three methods for building parameterizations with each other. Concluding we can say that the simulated energy demand complies with the measurement data mostly in a sufficient way as well as many deviations of simulated and measured data could be explained. Especially for entire city districts as shown in (Lauster 2013) even an approach with type building settings can display the thermal performance of large scale energy systems in an acceptable way.

INTRODUCTION

There are two ways for improving future energy supply, increase energy production efficiency so that the consumption of fossil fuels and CO₂-emissions decrease, and decrease end-use. Especially in the building sector with a significant share in German energy demand, combined heat and power (CHP) in conjunction with retrofitting buildings to decrease heat energy demand is a reasonable way to achieve the aims in energy policy. However, it does not make sense to optimize the energy production and consumption separately, particularly, if they are connected by district heating grids. We consider these networks as a third component that contains optimization potential.

Ideally, we optimize the entire large-scale energy system, so that we can consider interactions between these three parts and implement the most economically sensible activities first.

One way to identify this optimization potential is to develop an integral dynamic energy demand planning tool (Huber & Nytsch-Geussen 2011). In our current project, which focuses on research campuses as a special kind of city districts, we develop models to reflect the thermal behaviour of buildings, the thermo-hydraulic behaviour of the thermal networks

as well as the characteristics of CHPs or other heat sources.

This paper focuses on a simplified building model, which we implemented in the programming language Modelica with the simulation environment Dymola. Obviously, complex building models are not suitable for the simulation of entire city districts. To contribute to the challenges of parameterization effort and acceptable computation times for the simulation of entire city districts (Lauster 2012), we developed a simplified building model based on the German guideline VDI 6007 (VDI 2012), which will be described briefly in further context. As shown in (Lauster 2013), this model enables us to simulate more than 120 buildings for one year on an eight core PC in less than two hours with sufficient overall accuracy.

Therefore, the focus of this paper is on the validation of the simulated ideal energy demand from our simplified building model with real consumption data from measurements of five single buildings.

SIMULATION AND MEASUREMENT DATA COMPARING METHODS

Although as shown in (Oschatz 2008) the simulated or calculated energy demand often does not meet the measured consumption values, we use measured data for a comparison with various methods. The deviation of these data can be caused by influence factors such as user influence, deficiencies in building technology, simplifications in the simulation model or measurement errors.

On the one hand, we use graphical comparison methods and compare heat load curves. Besides, we use scatter diagrams to verify the correlation of simulated and measured data.

On the other hand, we used arithmetical methods such as relative errors for hourly data, based on different time horizons. The relative error for a single comparison is defined as difference between the simulated Q_{Sim} and measured hourly heat Q_{Ref} , divided by the measurement (Equation 1).

$$f = \frac{Q_{Sim} - Q_{Ref}}{Q_{Ref}} \quad (1)$$

The average relative error on hourly basis for a period is computed by summing up all relative errors and dividing the sum by the number of relative errors n_h (Equation 2).

$$\bar{f}_{hour} = \frac{1}{n_h} \sum_i^{n_h} \left(\frac{Q_{Sim,i} - Q_{Ref,i}}{Q_{Ref,i}} \right) \quad (2)$$

We determine the hourly error on basis of other periods such as weeks or the total period under observation as seen in Equation (3). Thus, in the selected period e.g. week it is possible, that positive and negative hourly relative errors balance each other. Then the absolute value of those errors is averaged, which leads to the total relative error on e.g. weekly base (Equation 3).

$$\bar{f}_w = \frac{1}{n_w + 1} \sum_j^{n_w} \left| \frac{1}{168} \sum_{k=j+1}^{j+168} \left(\frac{Q_{Sim,k} - Q_{Ref,k}}{Q_{Ref,k}} \right) \right| \quad (3)$$

Moreover, we calculate the relative error of the entire simulated and measured heat for the total period under observation (Equation 5).

$$f_{tot-eng} = \frac{Q_{Sim-total} - Q_{Ref-total}}{Q_{Ref-total}} \quad (4)$$

Furthermore, the coefficient of determination R^2 checks over the full period, if there is a linear correlation between the hourly measurement and simulation data.

$$R^2 = 1 - \frac{\sum(Q_{Sim} - Q_{Ref})^2}{\sum(Q_{Sim} - Q_{Sim})^2} \quad (5)$$

The more this coefficient is close to one, the higher is the linear correlation. Thus, for our application the coefficient of determination is one, if the simulation meets the measurement values and hence the bisecting line in the scatter plots of e.g. Figure 5 perfectly.

BUILDING MODEL

Our building Model is based on the German guideline VDI 6007 (VDI 2012), which simplifies the thermal behaviour of a building by converting it into an equivalent circuit of resistances and capacities in analogy to electrical circuits. It generally divides building components into asymmetrically and symmetrically thermally loaded components. In asymmetrically thermally loaded components, the temperature on one side of the component differs to the temperature on the other. Those components are exterior building components such as windows, walls or roofs. The symmetrically thermally loaded components are inner building components e.g. inner walls and inner floors.

In our model (Figure 1), the interior walls are assumed adiabatic so that they can be substituted by one capacity and one resistance. Hence, those walls

behave like thermal storages. In contrast to interior walls, the building can exchange energy with the environment through the exterior walls, so that these walls are represented by one capacity and two resistances. In addition to the inner and outer walls, there is an indoor part of the circuit, which considers thermal effects inside one zone such as solar radiation, long wave radiation and convective heat transfer.

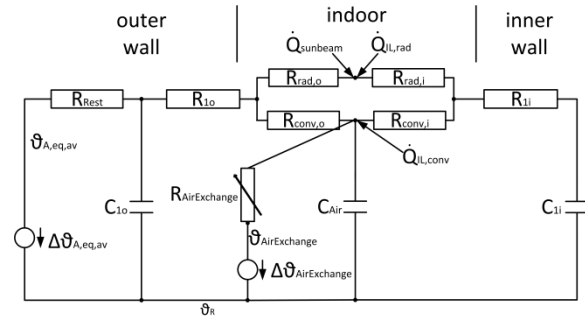

Figure 1 Electrical substitution circle for a thermal building zone

Differing from our model, the guideline neither takes the capacity of the air into account nor differentiates between radiation and convective heat transfer.

All outer elements are combined to one wall. To consider the orientations of the individual elements, the wall is connected to an equal air temperature. This temperature considers the radiation on differently oriented surfaces of variable size, the temperature of the ground as well as of the environment into account. It enables us with the aid of weight-factors to generate an average temperature for the exterior walls. In comparison to the guideline, we implemented some further changes.

Parameters describing the physical behaviour of a building are implemented in Dymola with the use of records. These text files contain for instance resistance and capacity of the electrical substitution circuit as well as typical inner loads such as light, people or machines. As presented in Table 1, we can generate those records in four different ways. Method A considers with the help of an Excel and Matlab tool every individual inner and outer wall, windows, their material, thickness, surface and orientation. Furthermore, this method (Mthd.) considers different building zones such as office with typical characteristics. Therefore, a high effort in parameterisation is needed as well as detailed knowledge about the building required. Method B is based on an approximate (approx.) zoning of a building, where we enter the exact wall mounting of outer walls and the approximate surface of inner and outer walls, roofs, number and height of floors as well as orientation for each zone.

For Method C we use the year of construction to generate typical wall mountings and further

characteristics based on data from (BMVBS 2010, Lichtmeß 2010).

For Method D, which only works sufficiently for office and residential buildings, the only input parameters needed are year of construction, number and height between floors as well as the total building area. Further parameters such as typical floor plans can be used optionally. This type building approach enables us to generate building records within minutes.

Table 1 Methods for building parameterization

Mthd.	Zoning	Wall mounting	Building configuration & orientation
A	detailed	detailed	detailed
B	approx.	detailed	approx.
C	approx.	Type	approx.
D	type	Type	type

Besides, the parameters describing the physical characteristics of a building, other parameters have to be entered separately, which can depend on the building zone:

- Air exchange rates
- Interior loads e.g. appliances, miscellaneous electric loads (MEL), lightning, occupants
- User profiles
- Heating and cooling temperature setpoints including night setback
- Weather data

These boundary conditions for different zones are mainly based on the norms DIN V 18599 (DIN 2007) and SIA 2024 (SIA 2006).

Building technology such as heat recovery is not implemented so far. Thus, exchanged air enters the building with the current ambient temperature.

SIMULATION OF BUILDINGS

In our project, we monitor two research campuses with district heating and cooling networks energetically and measure volume flows as well as temperatures. For one campus our project partners record measurement data of a high percentage of the buildings. On the other campus we use our own ultrasonic volume flow meters and temperature sensors in the thermal networks. For our validation, we choose five buildings (Bldg.) with three different years of construction, different type of use and different building areas as shown in Table 2. The oldest building is from 1960 and the newest from 2010, while the floor area varies from 395 m² up to 5877 m². The high number of chosen new buildings results from the fact that these buildings were equipped with measurement equipment first and for these buildings all building plans are available.

Table 2 Properties of simulated buildings

Bldg.	Year of construction	Floor area [m ²]	Utilization
1	2010	1182	Office
2	2010	1249	Laboratory
3	1969	3222	Office/ lab
4	2010	395	Office
5	1960	5877	Office / lab

The annual energy use per area ($Q_{Ref-Spec-a}$) varies from 20.3 kWh/m²a to 405 kWh/m²a (Table 3). Surprisingly, it is not possible to see a clear correlation between the year of construction and annual heat energy use per area, because the building with the highest annual heat energy use per area was built in 2010. Furthermore, the energy use per area for Bldg. 1 and 2 varies by the factor 20, although they were built in the same year. That results of the fact, that Bldg. 1 is a passive house with triple insulated windows and 240 mm insulation and Bldg. 2 a laboratory building. Besides, Table 3 shows the specific heat demand ($Q_{Calc-Spec-Gdepb-a}$), using the German directive energy performance of buildings, based on the German by-law EnEV 2009 (EnEV 2009).

Table 3 Measured annual heat energy use per area and calculated specific heat demand basing on the German directive energy performance of buildings

Bldg.	$Q_{Ref-Spec-a}$ [kWh/m ² a]	$Q_{Calc-Spec-Gdepb-a}$ [kWh/m ² a]
1	20.3	10.6
2	405	157
3	105	-
4	56	139.9
5	322	-

In comparison to the measurement data, which are not corrected by the degree-day method, the calculated demand and measured consumption varies up to a factor of two. For example, for Bldg. 1, the calculated energy demand is the half, for Bldg. 4, it is double of the measured energy.

Figure 2 shows the specific simulated heat energy demand based on type buildings (method D), for 50 % of the buildings (124 buildings) from one research campus. The bar shows the average demand and the black line the standard deviation of the simulations. We can see that just the consumption of Bldg. 5 matches with this simulation.

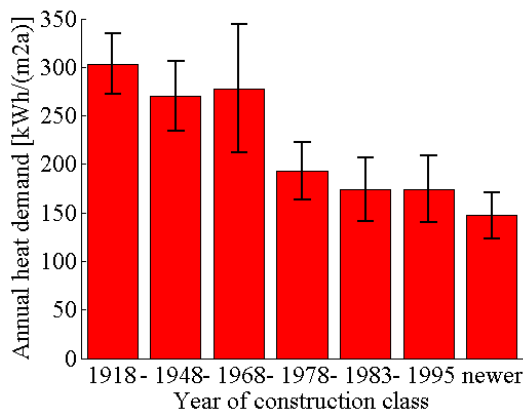

Figure 2 Typical energy demand depending on the date of construction (Source: Lauster 2013)

Therefore, these first comparisons already show the complexity of comparing measurement with calculation or simulation data.

Simulation with detailed parameterization

For a detailed building physics parameterization with method A, we select Bldg. 1 and 2. The effort for the parameterization of those medium scale buildings takes at least three days per building.

First tries with standard user and heating profiles showed, compared to measurement data, unacceptable results for Bldg. 1. Therefore, we decide to analyse the measurement data as well as the detailed utilization of these buildings. In Figure 3, which shows the measured heat power curve for Bldg. 1 for two chosen days, we can see that there is no heat consumption during night. Hence, we implemented a night setback in all buildings but Bldg. 5. This results from a measurement value analysis of Bldg. 5.

Furthermore, in Bldg. 1 the daily time of utilization seems to be longer than assumed in the norms.

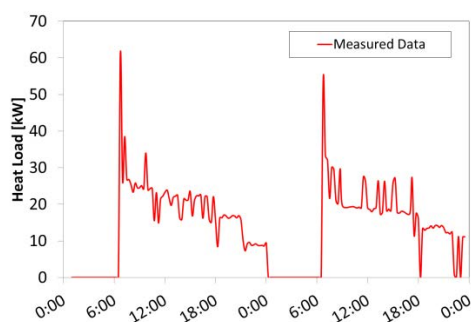

Figure 3 Heat power curve of Bldg. 1 for two typical weekdays

Therefore, we adapted the standard user profiles as well as the daily set temperature profiles. Two different ventilation models are implemented in this model, whereupon one model has the same ventilation rates for each week (method A-1) and the other ventilation rate depends on the user attendance

as well as the ambient temperature (method A-2). For example, this means, that on days with higher ambient temperatures and higher user activity, the air exchange rates increase.

In almost the same manner, Bldg. 2 deviates from the assumptions made in the norm. This building contains animal laboratories and clean rooms, which standards differs a lot from ordinary laboratories.

Simulation with approximate zoning

In contrast to the complex parameterization, these methods take, depending on the size of the building, just about a few hours. For this reason, we implemented all buildings with method B or C as shown in Table 4.

As revealed, all buildings' physics and heater properties of all buildings with the exception of Bldg. 1, are parameterized with standard values basing on (BMVBS 2010, Lichtmeß 2010, DIN 2007) using the typical materials (e.g. for walls) matching to the date of construction.

As Bldg. 1 is a passive house, we implemented the outer wall and insulation thicknesses as well as materials manually (method B). All air exchange rates but the ones for Bldg. 1 and the air exchange rates for animal laboratories are based on norms and depend on the user's presence and ambient temperatures (Dependent). For Bldg. 1, we use here the same air exchange rates as in method A-2.

Table 4 Building model parameterization

Bldg.	Mthd.	Air exchange rates	Utilization time /profile
1	A-1	Static adapted tables	adapted
1	A-2	Dependent	adapted
1	B	Dependent	adapted
1	D	Dependent	adapted
2	B	Dependent	adapted
2	C	Dependent	norms
3	C	Dependent	norms
4	C	Dependent	norms
5	C	Dependent	norms

Simulation with type buildings

To exhibit the difference in accuracy and complexity in usage, we parameterized Bldg. 1 with method D.

RESULTS, DISCUSSION AND RESULT ANALYSIS

In contrast to other methods for building model validation such as ASHRAE 140 (ASHRAE 2004) or the building model validation method according to EMPA (Swiss Federal Laboratories for Material Testing and Research) (Manz et al. 2006), we do not compare simulation results with other simulations for special test rooms and conditions. We compare simulation with measurement data and assume that

for the measurements no measurement errors exist. Additionally this building model is validated with the EMPA method (Wolisz et al. 2013).

Building 1

Bldg. 1 is our major test building simulated in this study. As presented in (Fuchs et al. 2012), the simplified building model parameterized with method A and constant air exchange rate profiles for each week, meets the measurement data especially for the total periods' amount of energy in an acceptable way. The difference of the total heat demand compared to measured consumption is only about 5.5% and the coefficient of determination with 0.66 comparatively high (Table 5). Besides, as shown in Figure 4, for a few chosen weeks (e.g. February 2012) the trend of the simulation and measurement curves are similar.

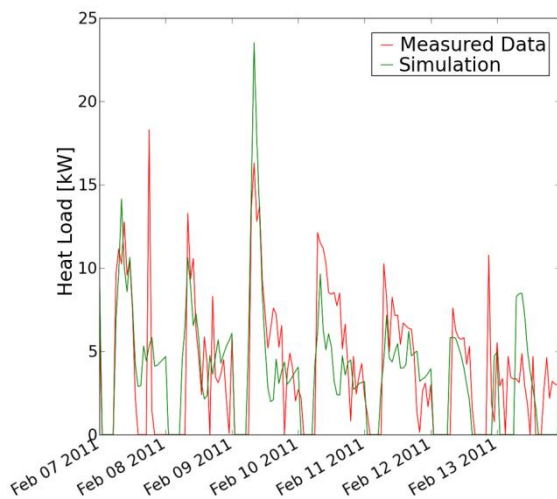

Figure 4 Comparison of measurement and simulation data for Bldg.1 with method A-1

In Figure 5 we can see that there is a linear correlation ($R^2=0.66$) between measurement and simulation data for Bldg.1 and method A-1.

Table 5 Relative errors and coefficient of determination for Bldg. 1 for the total period

Bldg.	\bar{f}_{hour}	\bar{f}_{week}	\bar{f}_{tot}	$f_{tot-eng}$	R^2
1-A-1	0.3	0.137	0.032	0.055	0.66
1-A-2	0.32	0.176	0.013	-0.076	0.58
1-B	0.295	0.143	0.015	-0.074	0.55
1-D	2.7	2.7	2.7	5.9	-0.89

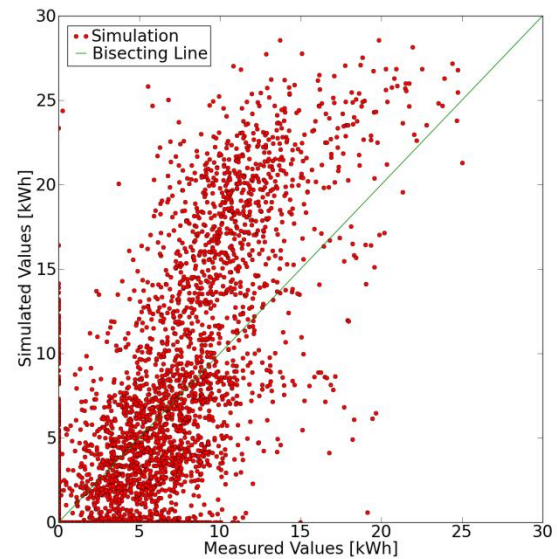

Figure 5 Dependency of simulation and measurement data of Bldg. 1 with method A-1 for the total period

In comparison to method A-1, the results for method A-2 are nearly as good (Table 5). Even the relative error on hourly basis for the total period is lower than before. We can see, that caused by changes of ventilation rates, the total heat simulation varies by more than 10 %, so that the influence of air exchange rates is probably high.

Surprisingly, the third version of Bldg. 1, which we parameterized with method B (detailed wall mounting), reveals partly slightly better result (e.g. $\bar{f}_{hour}=0.295$) than with method A-1 and A-2. The hourly relative errors are less than 30 % and the difference between measured and simulated heat in the entire period is only about 7 %. Figure 6 illustrates the acceptable linear correlation ($R^2=0.55$) of measurement and simulation data. Thus, these results indicate that other factors such as air exchange rates or exact wall mountings seem to have a higher influence on the energy demand for this building than the exact implementation of every single room with its' inner and outer walls.

As expected, the fourth version of Bldg. 1 did not match the measurement data adequately ($R^2 = -0.89$). The standard building wall mountings for this date of construction do not meet with the passive house characteristics. Therefore, the simulated energy exceeds the measurement data by the factor of six and all other relative errors are more than 200%. This leads to the fact, that this way of building model parameterization is not suitable for passive house buildings.

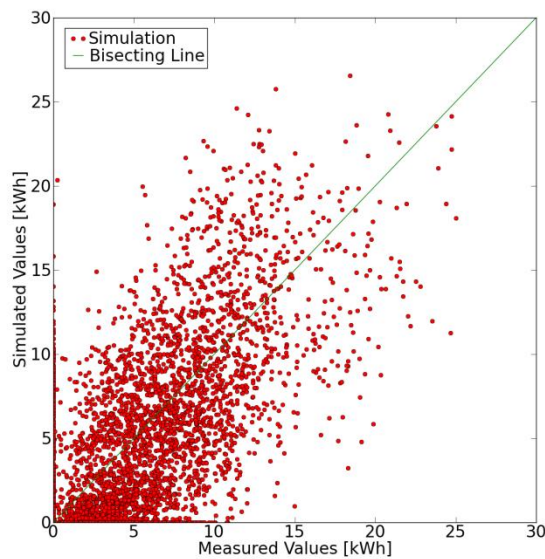

Figure 6 Dependency of simulation and measurement data of Bldg. 1 with method B for the total period

Other Buildings

Table 7 exhibits that the other buildings meet the measurement data with strongly varying accuracy.

As shown in Table 7 the simulation for Bldg. 2 and 3 deviate clearly from the measurement values. The coefficient of performance exhibits (R^2 is negative), that there exists no linear correlation between the compared data for Bldg. 2. The total amount of simulated heat is even less than a third of the energy consumed in reality, whereupon the version parameterized with method C is better.

Table 7 Relative errors and coefficient of determination for Bldg. 2,3,4,5 for the total period

Bldg.	\bar{f}_{hour}	\bar{f}_{week}	\bar{f}_{tot}	$f_{tot-eng}$	R^2
2-A	1.44	0.82	0.09	-0.743	-79
2-C	0.93	0.63	0.5	-0.68	-62
3-C	2.1	1.46	1.35	0.36	0.45
4-C	2	1.7	1.7	1.2	-0.6
5-C	0.44	0.32	0.26	-0.12	0.86

This difference between measurement and simulation data we expected before, because the annual heat energy per area of Bldg. 2 is more than the double of a typical building with the same year of construction. Probably this results from the fact, that this building is a laboratory building, which contains animal labs, clean rooms, a high rate of technical building technology as well as unknown heat sources such as an autoclave. Maximum air exchange reach values up to 40 and the humidity of the air is defined on certain values, even at weekends. Furthermore, a heat recovery system exists. Those factors lead to the fact, that without building technology models and knowledge about the real performance of this building technology, it is not possible to simulate this

building in a sufficient way. The same discrepancy of measured and simulated data, we can see for Bldg. 3 (e.g. $\bar{f}_{hour} = 2$) in Figure 7, where the simulated heat load exceeds the measurement clearly. However, during the weekends (e.g. 21st or 22nd. of January) the curves comply in a better way. An explanation for that discrepancy could be that our model meets the physical behaviour of the building without the influence of the user and building technology as it happens on weekends sufficiently. Therefore, this building probably contains a heat recovery system.

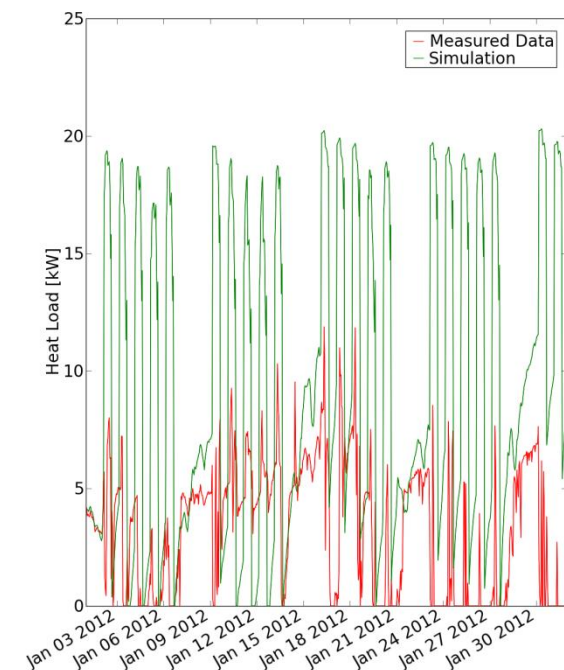

Figure 7 Comparison of measurement and simulation data for Bldg. 3

Although all relative errors on hourly basis of Bldg. 4 exceed 100%, the total simulated and measured heat varies about only about 36 % and the coefficient of determination is 0.45. A possible reason for those high errors could be that the heating is switched off during summer months. The simulated and measured heat load curves behave similarly for Bldg. 3. During weekdays the simulated heat demand is higher than the measured and at weekends the data are quite similar. This probably results of the installation of a new technical building technology system in 2003. Therefore, this old building consumes less energy than expected due to a heat recovery system.

The best results, we can see for the oldest (1960) and biggest building. The coefficient of determination is with 0.86 the highest of all test buildings. In addition, we can see this correlation in Figure 8. The simulated and consumed energy for the total period varies only about 12 %. Figure 9 shows the dynamic simulated and measured heat load curves, where the simulation and measurement meet in an acceptable way. Especially the peaks of maximum heat load and average level of both data are similar.

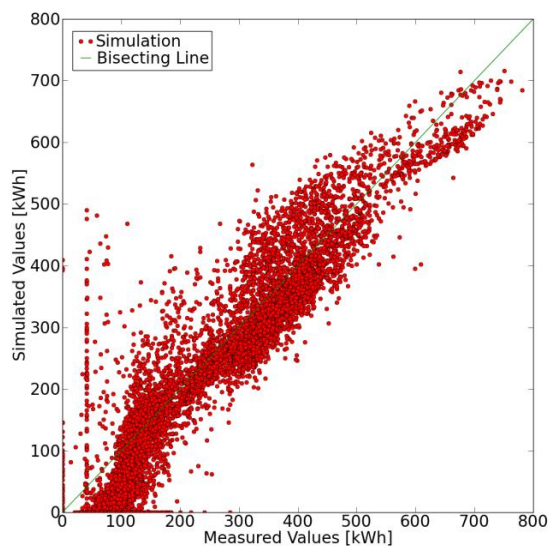

Figure 8 Dependency between simulation and measurement data for Bldg. 5 for the total period

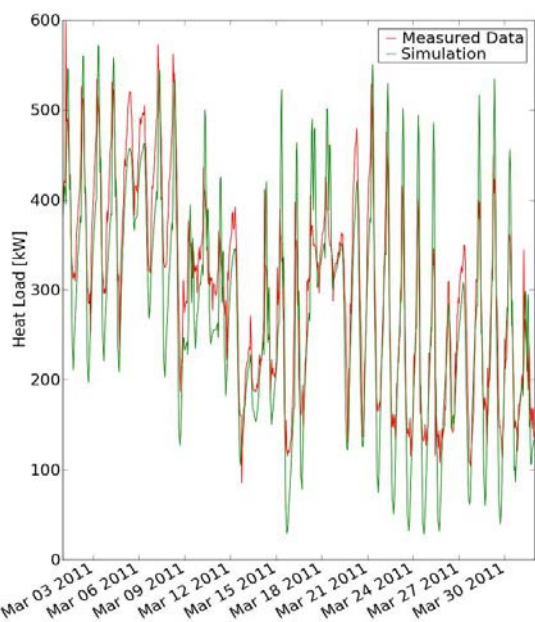

Figure 9 Comparison of measurement and simulation data for Bldg. 5

CONCLUSION AND OUTLOOK

As expected and shown in (Oschatz 2008), the comparison of simulated energy demand and real consumption data from measurements did not show perfect compliance nor for each building the same accuracy. The reason for this seems to be that the preciseness of our simplified building model depends on diverse factors such as:

- Method of parameterization
- Utilization of the building
 - User behavior e.g. utilization time
 - Air exchange rates
 - Typical inner loads
- Year of construction

- Installed technical equipment

One major influence factor on the simulated energy demand of a building is the method of parameterization. This results from the fact, that the outer shape of a building, the geographical adjustment or the real building material are not fully considered by method C and D. Especially for passive houses it is necessary to know at least the fact, that this building is a passive house, as shown for Bldg. 1. The same applies for retrofitted buildings. If this is considered, method B seems to be not less adequate than method A, while the effort of parameterization is much less. Therefore, it seems to be appropriate for a fast simulation of single passive or retrofitted buildings. As shown, the results gained with method D vary a lot compared to the other parameterizations for the tested building and it seems to be not recommendable for the dynamic simulation of any single building. But as shown in (Lauster 2013) this method works sufficiently well for simulating entire city districts.

Especially the user as well as the utilization (e.g. laboratory utilization) of a building have a high influence on the heat energy consumption. By opening windows, the utilization of machines or the user's attendance, the user can influence the heat consumption in a strong way. For Bldg. 1 we found out that probably the user's attendance does not match with the standard attendance profiles from the norms. The magnitude of the user influence can be seen well in the performance of Bldg. 3 or 4. There the measurement and simulation fit on several weekends acceptable, but during the week the difference is big. As shown for Bldg. 2, the building's utilization can have a high influence on the energy consumption. There, the air exchange rates as well as the energy needed for dehumidification of the animal laboratories and clean rooms, do not match with ordinary laboratories. Furthermore, special internal heat sources (e.g. autoclave in Bldg. 2) or sinks can either decrease or increase the heat demand of a building and make a simulation difficult.

For two equal buildings with the same utilization the energy consumption does not have to be congruent, because technical building technology plays an important role. For example heat recovery systems, night setbacks as well as air exchange rates forced by ventilation engineering can influence the heating demand and profile in a significant way. Particular Bldg. 4 which was built in 1969 and equipped with new building technology in 2003, consumes less heat energy per square meter than a typical building from this date of construction (BMVBS 2010). For the laboratory Bldg. 2 we made the same observation in the opposite way.

For the accuracy of our model, the date of construction seems to be an influence factor, because for older building the part of the energy consumption

caused by the pure building physics has a higher ratio of total consumption than for newer buildings. Furthermore, those buildings often contain less building technology.

Concluding we can say that the simulated energy demand from our simplified building model mostly complies with measured consumption data of five selected buildings in a sufficient way. Many deviations of simulated and measured data could be explained. As the comparison with special theoretic test buildings (e.g. EMPA validation) revealed acceptable results, this building model seems to fulfill our requirements. Especially for entire city districts as shown in (Lauster, 2013) even the type building approach (method D) can display the thermal performance of large scale energy systems in an acceptable way.

In order to cope with some of the problems pointed out and to improve our model, we currently develop building technology models, especially heat recovery systems and design statistical user profiles.

NOMENCLATURE

approx.	= approximate
Bldg.	= building
CHP	= combined heat and power
f	= relative error
\bar{f}_{hour}	= relative error on hourly base for the total given period
\bar{f}_w	= relative error on hourly base for the certain period
$f_{tot-eng}$	= relative error for total heat
Mthd.	= method
R^2	= coefficient of determination
tot	= total period
Q_{Ref}	= measured heat
$Q_{Ref-Spec-a}$	= annual energy use per area
Q_{Sim}	= simulated heat
$Q_{Calc-Spec-Gdep-a}$	= specific energy demand based on German directive energy performance of buildings

ACKNOWLEDGEMENT

Grateful acknowledgement is made for financial support by German Federal Ministry of Economics and Technology), promotional reference 03ET1004A.

REFERENCES

ASHRAE 2004. ASHRAE 140-2004 - Standard Method of Test for the Evaluation of Building Energy Analysis Computer Programs, Atlanta, USA.

BMVBS [German Federal Ministry of Transport, Building and Urban Development]. 2010. Vereinfachung zur geometrischen und technischen Datenaufnahme im Nichtwohngebäudebestand, BMVBS-Online-Publikation 26/2010.

DIN [German Institute for Standardization] 2007. DIN V 18599 - 10 Energy efficiency of buildings - Calculation of the net, final and primary energy demand for heating, cooling, ventilation, domestic hot water and lighting - Part 10: Boundary conditions of use, climatic data, Berlin, Germany: Beuth Verlag GmbH.

Fuchs, M., Lauster, M., Teichmann, J., et al. 2012. Modularer Modellansatz zur Simulation von Energiesystemen auf Quartiersebene, Proceedings of BauSIM 2012, IBPSA Germany, Berlin, Germany.

EnEV 2009 2009. EnEV 2009-Energieeinsparverordnung für Gebäude, German by-law, Berlin, Germany.

Lauster, M. 2012. Modelica Building-Bibliothek und Gebäudemodelle, Proceedings of Symposium Integrale Planung und Simulation in Bauphysik und Gebäudetechnik 2012, Dresden, Germany.

Lauster, M., Fuchs, M., Teichmann, J., et al. 2013. Energetic Simulation of a Research Area with typical Building Settings, This issue.

Lichtmeß, M. 2010. Vereinfachungen für die energetische Bewertung von Gebäuden, Bergische Universität Wuppertal, Architektur. Wuppertal, Bergische Universität Wuppertal, Germany.

Huber, J., Nytsch-Geusen, C. 2011. Development of Modeling and Simulation Strategies for Large-Scale Urban Districts. Proceedings of Building Simulation 2011 (pp. 1753-1760), Sydney, Australia: International Building Performance Simulation Association.

Manz, H., Loutzenhiser P, Frank, T., et al. 2006. Series of Experiments for Empirical Validation of Solar Gain Modeling in Building Energy Simulation Codes - Experimental Setup, Test Cell Characterization, Specifications and Uncertainty Analysis, Building and Environment, 41 (12) 2006. Pages 1784-1797.

Oschatz, B. 2008. Leitfaden zum Abgleich Energiebedarf-Energieverbrauch, Fraunhofer IRB Verlag.

SIA, Swiss society of engineers and architects. 2006. SIA bulletin 2024 Standard-conditions for energy- and building equipment, Zurich, Switzerland: SIA Zurich.

VDI 6007, German association of engineers. 2012. Calculation of transient thermal response of rooms and buildings, VDI-Guideline, Beuth Verlag, Berlin, Germany.

Wolisz, H. et al. 2013. Dynamic simulation of thermal capacity and charging/ discharging performance for sensible heat storage in building wall mass, This issue.